

| DATE | REV. | DESCRIPTION | DRN | APPD |
|-----------|------|-----------------|-----|------|
| 12-AUG-10 | 01 | INITIAL RELEASE | RJA | |

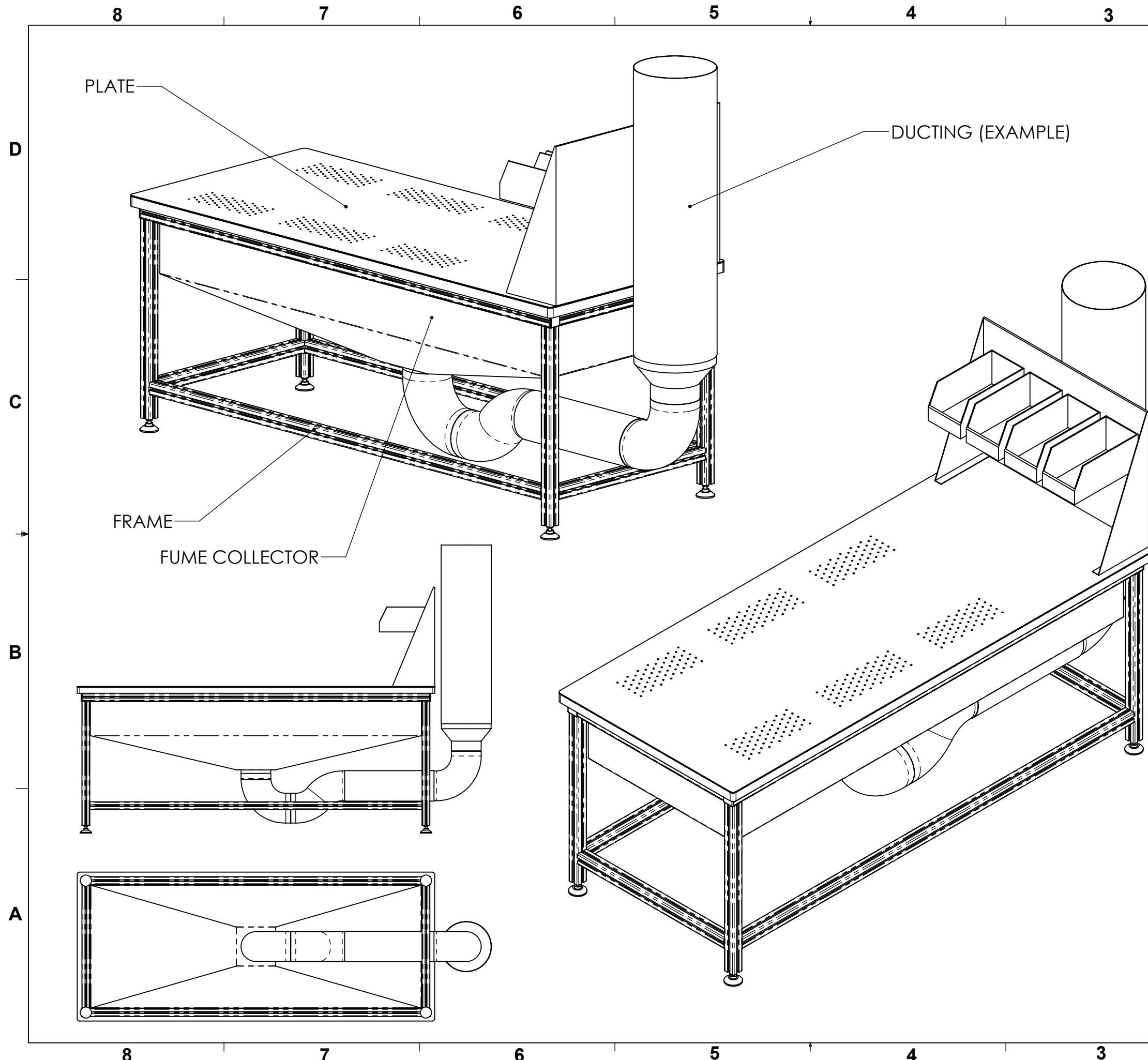

MATERIAL SPECIFICATIONS

DIMENSIONAL NOTES

D1. THE MASTER SOURCE OF INFORMATION FOR THIS DRAWING IS A COMPUTER DATABASE.
D2. DO NOT SCALE PRINT.

REGULATORY CHARACTERISTICS

GENERAL NOTES

| NAME | DATE | INTERPRET DIMENSIONS AND TOLERANCES PER ISO 1101, 128, 129 |
|---------------------|-----------|--|
| DRAWN BY: R.ANDRADE | 12-AUG-10 | |

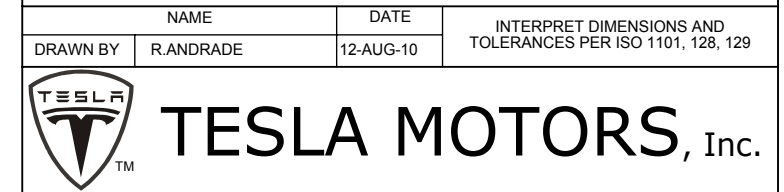

THE INFORMATION CONTAINED HEREIN IS DEEMED TO BE CONFIDENTIAL, PROPRIETARY, AND A TRADE SECRET OF TESLA MOTORS. THIS INFORMATION MAY NOT BE USED, REPRODUCED, OR DISCLOSED AS THE DIRECT OR INDIRECT BASIS FOR THE DEVELOPMENT, MANUFACTURE, OR SALE OF PROCESSES OR PRODUCTS WITHOUT THE EXPRESSED WRITTEN CONSENT OF TESLA MOTORS.

MATERIAL:

FINISH: EST. WEIGHT (g):

| | | | |
|------------------------|--|---------------|-----------------|
| THIRD ANGLE PROJECTION | DIMENSIONS ARE IN INCHES TOLERANCES: ANGULAR ±0.5° FRACTIONAL ±1 DECIMALS X ±0.3 X.XX ±0.10 | SCALE 1:20 | SHEET SIZE B |
|------------------------|--|---------------|-----------------|

ITEM NAME:
ASSEMBLY,MMB-DOWNDRAFT-TABLE,METRO-MFG

| MAT'L NO. | ITEM NO. | REVISION | SHEET |
|-----------|----------|----------|--------|
| | | 01 | 1 OF 2 |

REV 01

A

| DATE | REV. | DESCRIPTION | DRN | APPD |
|-----------|------|-----------------|-----|------|
| 12-AUG-10 | 01 | INITIAL RELEASE | RJA | |

MATERIAL SPECIFICATIONS

DIMENSIONAL NOTES

D1. THE MASTER SOURCE OF INFORMATION FOR THIS DRAWING IS A COMPUTER DATABASE.
D2. DO NOT SCALE PRINT.

REGULATORY CHARACTERISTICS

GENERAL NOTES

| NAME | DATE | INTERPRET DIMENSIONS AND TOLERANCES PER ISO 1101, 128, 129 |
|---------------------|-----------|--|
| DRAWN BY: R.ANDRADE | 12-AUG-10 | |



TESLA MOTORS, Inc.

THE INFORMATION CONTAINED HEREIN IS DEEMED TO BE CONFIDENTIAL, PROPRIETARY, AND A TRADE SECRET OF TESLA MOTORS. THIS INFORMATION MAY NOT BE USED, REPRODUCED, OR DISCLOSED AS THE DIRECT OR INDIRECT BASIS FOR THE DEVELOPMENT, MANUFACTURE, OR SALE OF PROCESSES OR PRODUCTS WITHOUT THE EXPRESSED WRITTEN CONSENT OF TESLA MOTORS.

MATERIAL:

FINISH:

EST. WEIGHT (g):

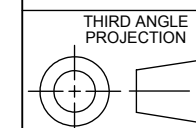

DIMENSIONS ARE IN INCHES

TOLERANCES:
ANGULAR ±0.5°
FRACTIONAL ±1
DECIMALS X ±0.3
X.X ±0.3
X.XX ±0.10

SCALE

1:12

SHEET SIZE

B

ITEM NAME:

ASSEMBLY,MMB-DOWNDRAFT-TABLE,METRO-MFG

| MAT'L NO. | ITEM NO. | REVISION | SHEET |
|-----------|----------|----------|--------|
| | | 01 | 2 OF 2 |

8 7 6 5 4 3

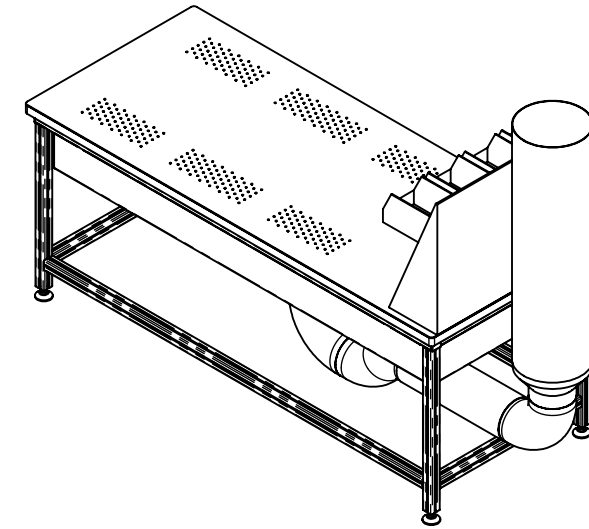
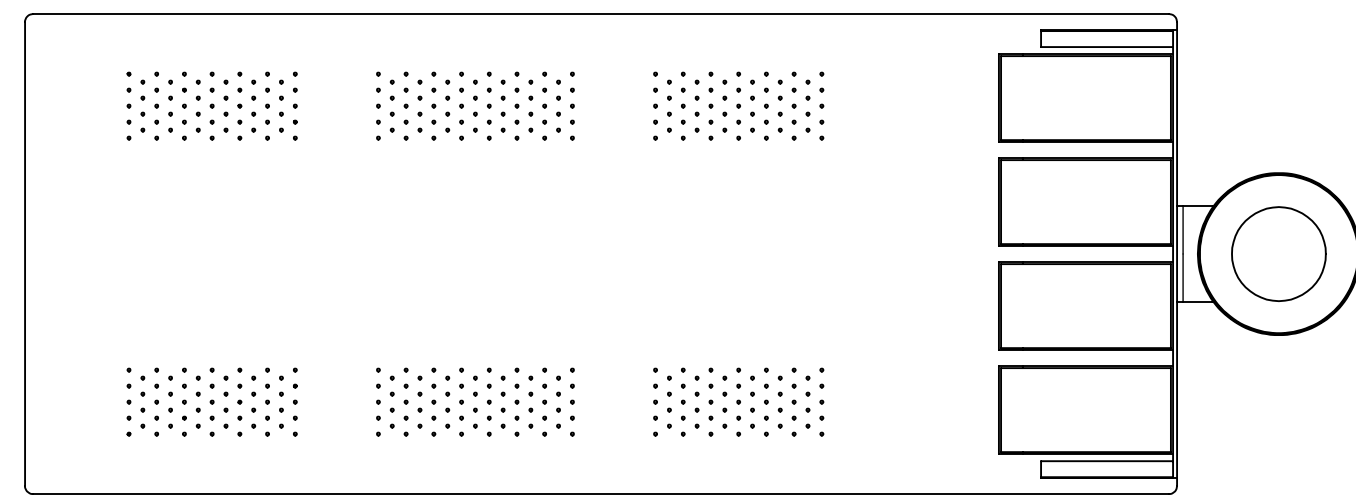

D

D

C

C

B

A

REV 01

A

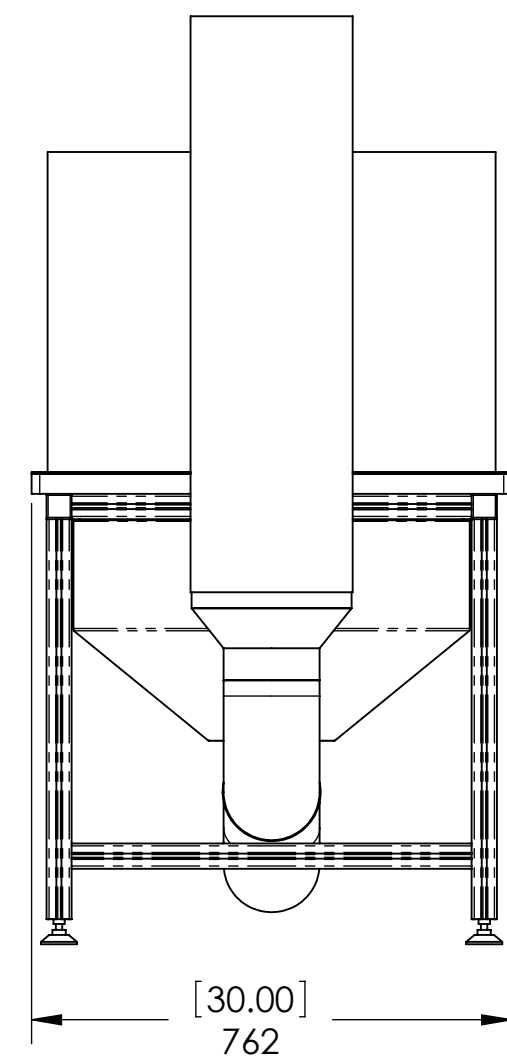
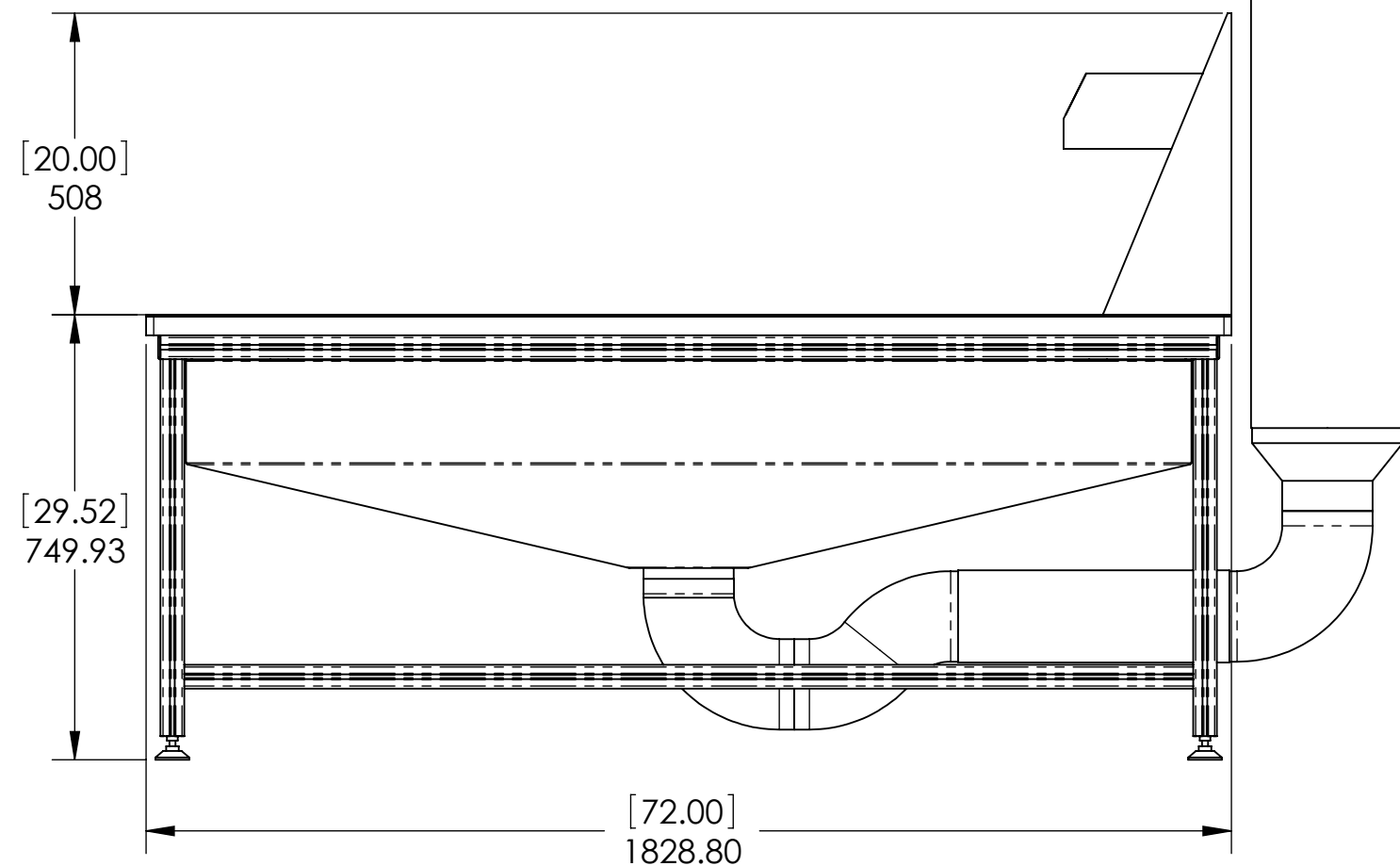

8 7 6 5 4 3

2 1